

Phi Group
(a trading division of Keller Limited)

Hadley House
Bayshill Road
Cheltenham
Gloucestershire GL50 3AW
Tel: 01242 707600
e-mail: southern@phigroup.co.uk
website: www.phigroup.co.uk



Agrément Certificate
95/3115
Product Sheet 1

PHI WALL SYSTEMS

PERMACRIB RETAINING WALL SYSTEM

This Agrément Certificate Product Sheet⁽¹⁾ relates to the Permacrib Retaining Wall System, comprising interlocking preservative-treated Radiata Pine timber headers and stretchers infilled with specified material to form an earth-retaining wall.

(1) Hereinafter referred to as 'Certificate'.

CERTIFICATION INCLUDES:

- factors relating to compliance with Building Regulations where applicable
- factors relating to additional non-regulatory information where applicable
- independently verified technical specification
- assessment criteria and technical investigations
- design considerations
- installation guidance
- regular surveillance of production
- formal three-yearly review.



KEY FACTORS ASSESSED

Structural performance — the system components, when used in accordance with this Certificate, have satisfactory structural characteristics when used in an earth-retaining wall system (see section 5).

Durability — the system, when constructed in accordance with this Certificate, can achieve a design life of 60 years (see section 9).

The BBA has awarded this Certificate to the company named above for the system described herein. This system has been assessed by the BBA as being fit for its intended use provided it is installed, used and maintained as set out in this Certificate.

On behalf of the British Board of Agrément

Simon Wroe
Head of Approvals — Engineering

Claire Curtis-Thomas
Chief Executive

Date of First issue: 3 March 2016

Originally certificated on 28 March 1995

The BBA is a UKAS accredited certification body — Number 113. The schedule of the current scope of accreditation for product certification is available in pdf format via the UKAS link on the BBA website at www.bbacerts.co.uk

Readers are advised to check the validity and latest issue number of this Agrément Certificate by either referring to the BBA website or contacting the BBA direct.

British Board of Agrément
Bucknalls Lane
Watford
Herts WD25 9BA

tel: 01923 665300
fax: 01923 665301
clientservices@bba.star.co.uk
www.bbacerts.co.uk

©2016

Regulations

In the opinion of the BBA, the Permacrib Retaining Wall System, if installed, used and maintained in accordance with this Certificate, can satisfy or contribute to satisfying the relevant requirements of the following Building Regulations (the presence of a UK map indicates that the subject is related to the Building Regulations in the region or regions of the UK depicted):



The Building Regulations 2010 (England and Wales) (as amended)

Requirement: A1 Loading
Comment: The system has sufficient strength and stability to satisfy this Requirement, provided it is designed in accordance with section 5 of this Certificate.

Regulation: 7 Materials and workmanship
Comment: The system is acceptable. See section 9 and the *Installation* part of this Certificate.

In addition to the contribution Permacrib Retaining Walls can make to meeting the relevant requirements, the following comments should be noted:

Requirement: A2 Ground movement
Comment: The effect on buildings adjacent to the walls will need to be considered.



The Building (Scotland) Regulations 2004 (as amended)

Regulation: 8(1) Durability, workmanship and fitness of materials
Comment: A wall incorporating the system can contribute to a construction satisfying this Regulation. See section 9 and the *Installation* part of this Certificate

Regulation: 9 Building standards applicable to construction
Standard: 1.1(a) Structure
Comment: A wall incorporating the system has sufficient strength and stability provided it is designed in accordance with section 5 of this Certificate, with reference to clause 1.1.1⁽¹⁾⁽²⁾ of this Standard.

Standard: 7.1(a) Statement of sustainability
Comment: The system can contribute to meeting the relevant requirements of Regulation 9, Standards 1 to 6 and therefore will contribute to a construction meeting a bronze level of sustainability as defined in this Standard.
(1) Technical Handbook (Domestic).
(2) Technical Handbook (Non-Domestic).



The Building Regulations (Northern Ireland) 2012 (as amended)

Regulation: 23 Fitness of materials and workmanship
Comment: The system is acceptable. See section 9 and the *Installation* part of this Certificate.

Regulation: 30 Stability
Comment: A wall incorporating the system has sufficient strength and stability to satisfy this Regulation provided it is designed in accordance with the requirements of section 5 of this Certificate.

Construction (Design and Management) Regulations 2015

Construction (Design and Management) Regulations (Northern Ireland) 2007

Information in this Certificate may assist the client, Principal Designer/CDM co-ordinator, designer and contractors to address their obligations under these Regulations.

See sections: 3 *Delivery and site handling* (3.1, 3.2 and 3.4) and 10 *General* (10.1) of this Certificate.

Technical Specification

1 Description

1.1 The Permacrib Retaining Wall System comprises interlocking, prefabricated, preservative-treated Radiata Pine timber headers, stretchers and header support blocks. The stretchers form the front and back of the wall and the headers tie the two faces together (see Figure 1).

Figure 1 General layout

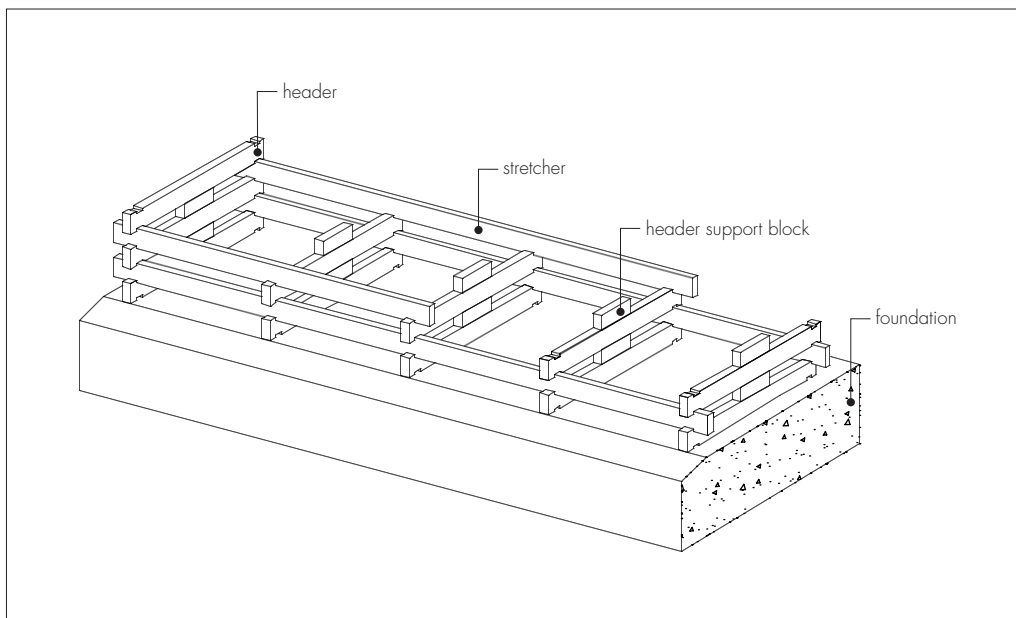

1.2 The system is available in eight header sizes (models). Stretchers vary in size depending on the header size used (see Figure 2).

1.3 Header support blocks are available with profile dimensions to match the headers.

Figure 2 System components

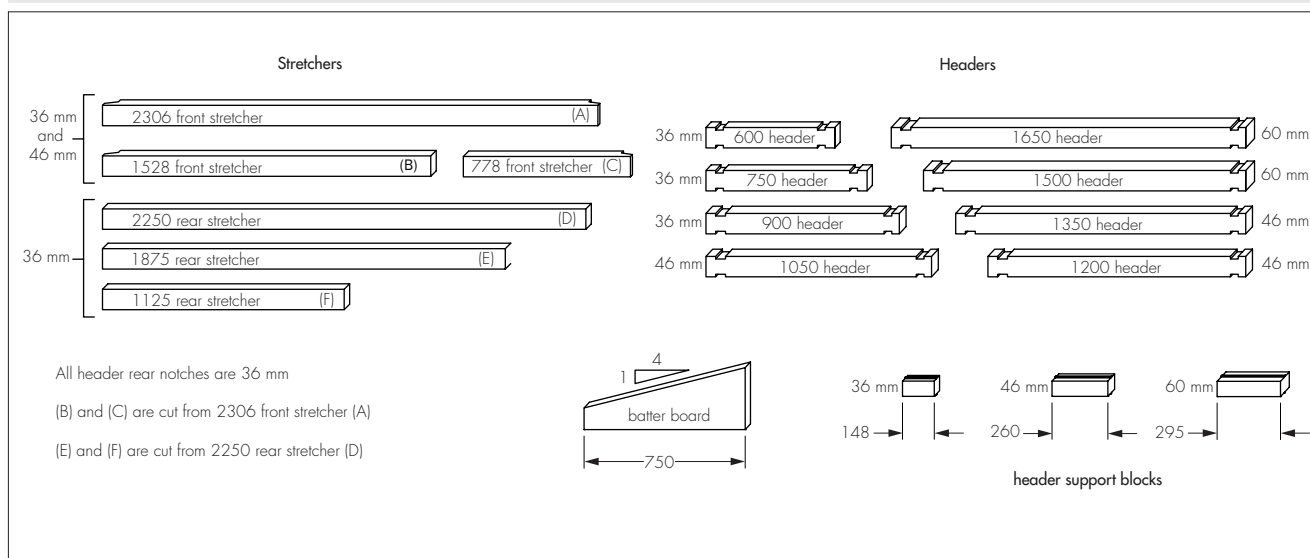

1.4 The crib fill material must be clean, free-draining, well-graded, crushed natural gravel, crushed rock (other than argillaceous rock), river gravel, recycled aggregate (except asphalt) or crushed concrete, and should fall within the grading bands shown in Table 1.

Table 1 Infill specification

Option 1 – graded stone ⁽¹⁾		Option 2 – clean stone ⁽¹⁾		Option 3 MCHW, Volume 1, Series 600
BS sieve (mm)	% passing	BS sieve (mm)	% passing	
75	100	90	100	Infill material must be supplied in accordance with Class 6f2 or 6f5
37.5	40–85	37.5	10–75	
5.0	5–35	20	0–15	
75µm	0–10	5	0–5	

Note: Uniformity coefficient to be greater than 10.

(1) Defined and tested in accordance with BS EN 1997-2 : 2007.

2 Manufacture

2.1 Radiata Pine timber components are cut to the required dimensions and pressure-treated to a level meeting the requirements of BS 8417 : 2011 for service use in a European Hazard Class 4 environment.

2.2 As part of the assessment and ongoing surveillance of product quality, the BBA has:

- agreed with the manufacturer the quality control procedures and product testing to be undertaken
- assessed and agreed the quality control operated over batches of incoming materials
- monitored the production process and verified that it is in accordance with the documented process
- evaluated the process for management of nonconformities
- checked that equipment has been properly tested and calibrated
- undertaken to carry out the above measures on a regular basis through a surveillance process, to verify that the specifications and quality control operated by the manufacturer are being maintained.

3 Delivery and site handling

3.1 The components are delivered to site banded together on pallets. Components should be stored on flat, level ground, as close to the building location as possible.

3.2 When handling, routine precautions, ie wearing of personal protective equipment and adherence to manual handling polices, should be followed.

3.3 The timber members can withstand normal site handling and fixing. Damaged timber must not be used.

3.4 Precautions against dust inhalation and eye contact are necessary when the treated timber is machine-cut or crafted. Permacrib members are supplied ready for assembly, but if members are cut on site the cut ends should be generously brushed with a wood preservative approved by the Certificate holder to a level meeting the requirement for surviving use in a European Hazard Class 4 environment.

Assessment and Technical Investigations

The following is a summary of the assessment and technical investigations carried out on the Permacrib Retaining Wall System.

Design Considerations

4 General

The Permacrib Retaining Wall System is satisfactory for use in providing an earth-retaining structure, with stability achieved through interaction of the crib components and the infill.

5 Structural performance



5.1 The design method is based on the limit state principles, in accordance with BS 8002 : 2015 and BS EN 1997-1 : 2004, and employs the monolith theory (gravity walls) for external stability.

5.2 The backfill, surrounding soil and site conditions have to be regarded as a whole. Site-specific parameters relating to soil, ground condition and ground water must be obtained by site investigation, laboratory testing or assessment. For this reason, the design and the supervision of the design must be carried out by a suitably-qualified/competent engineer.

5.3 In-situ soil conditions can vary from those assumed in design. These conditions must, therefore, be inspected immediately prior to and during wall construction, to ensure that any variation is noted, and the design reassessed accordingly.

5.4 The walls are flexible and can accommodate differential settlement.

5.5 Where an excavation is made to accommodate a wall, the undisturbed in-situ material may have differing properties to those of the backfill. This must be taken into consideration in the design (see sections 5.2 and 5.3).

Figure 3 Notation

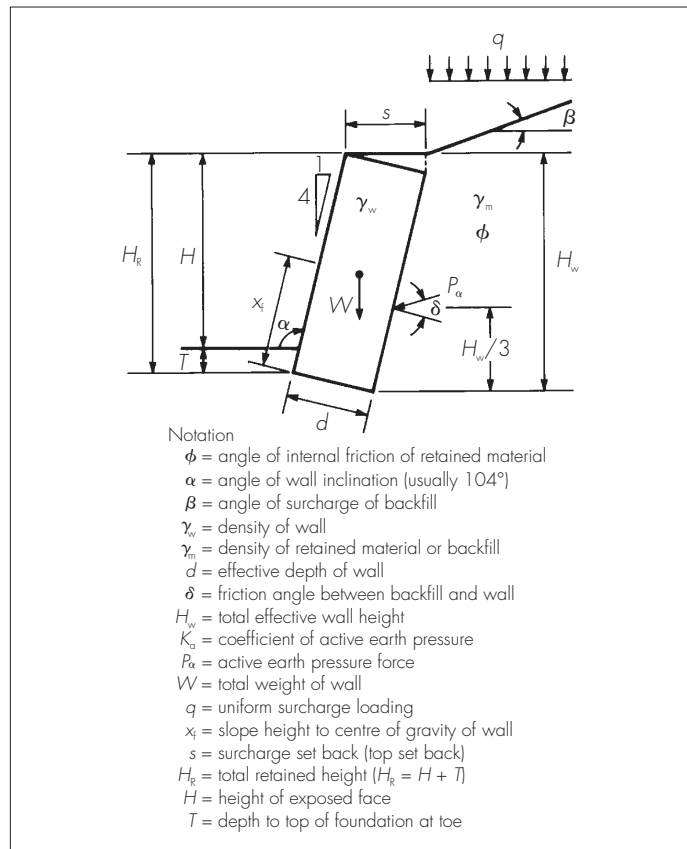

5.6 Where construction loading is greater than $10 \text{ kN}\cdot\text{m}^{-2}$, guidance from the Certificate holder should be sought.

5.7 Where the system is used in areas accessible to vehicles, consideration should be given to protection against damage by vehicle impacts.

5.8 Where the backfill is free-draining and extends to the critical failure plane, the possibility of hydrostatic pressure above the lowest drainage point may be excluded from the design. However, where seepage above wall-base level is anticipated or found during construction, specialist advice should be sought.

5.9 The requirements for the inclusion of header support blocks are given in Table 2.

Table 2 Header support block (HSB) — depth below top of wall in millimetres

Header	HSB size	Number of HSBs				
		1	2	3	4	5
600	148	766	1893	—	—	—
750	148	766	1893	3181	—	—
900	148	766	1893	2859	3664	—
1050	260	766	2537	4469	—	—
1200	260	766	2537	4147	—	—
1350	260	766	2537	3825	5113	—
1500	295	927	3020	4630	6401	—
1650	295	927	2859	4469	5918	7367

6 Practicability of installation

The product is designed to be installed by trained contractors experienced with this type of construction.

7 Wall system selection

7.1 The wall model selected is dependent upon the site conditions, soil properties, height of soil to be retained, additional loads imposed on the wall, design factors of safety and site conditions. Table 3 gives typical wall heights using the following site parameters:

- the angle of internal friction (ϕ_w) of the wall infill and backfill was taken as 35°
- the unit weight (γ) of the Permacrib and backfill was taken as $18 \text{ kN}\cdot\text{m}^{-3}$
- the angle of friction (δ) between the infill Permacrib and concrete was taken as 30° .

Table 3 Typical wall heights

Wall model	Height (m)
600	1.25
750	2.28
900	3.02
1050	3.50
1200	4.25
1350	4.79
1500	5.11
1650	5.92

Note: Data presented in Table 3 are for general guidance only and confirmation of design should be sought from the Certificate holder or competent engineer.

7.2 Owing to the variable nature of soils, this assessment does not include consideration of foundations to the walls. The bearing capacity of the ground and possible sliding at the underside of the foundation or through the underlying soils should be considered separately. Guidance is given in BS EN 1997-1 : 2004.

The maximum imposed foundation pressures for the wall heights given in Table 3 will not usually exceed the values given in Table 4.

Table 4 Maximum imposed foundation pressure

Wall model	Maximum bearing pressure (kN.m ⁻²)
600	75
750	100
900	125
1050	150
1200	175
1350	200
1500	specific design
1650	specific design

7.3 Typical values for the angle of internal friction are given in Table 5. The values given for clay soils apply only to intact soil; much lower values apply if the clay has been sheared by previous ground movements or where poorly-compacted clay fill is involved (see section 5.2).

Table 5 Typical design values of angle of internal friction

Soil type	Angle of internal friction (φ)	
Clay – Plasticity index	15	27° ⁽¹⁾
	30	24° ⁽¹⁾
	50	21° ⁽¹⁾
	80	18° ⁽¹⁾
Silt and silty sand, loose sand	30°	
Dense sand and sandy gravel	35°	
Dense, well-graded gravel or rock	40°	

(1) Values in accordance with BS 8002 : 2015.

8 Maintenance

8.1 There are no specific maintenance requirements for the retaining wall components. However, periodic inspections should be carried out for evidence of physical damage, unwanted plant growth or crib infill contamination from outside sources.

8.2 Any damage should be rectified promptly. The techniques for repair are not covered by this Certificate and advice should be sought from the Certificate holder.

8.3 Any plant growths which are not within areas approved in the original design should be removed to prevent accumulation of leaf litter and other organic debris, and to avoid disturbance by root growth.

8.4 The development of adjacent planted areas or landscaping should include precautions to avoid contamination of the crib infill by fines or organic debris.

9 Durability



9.1 The system components are made from Radiata Pine timber which is impregnated with a high-concentration copper azole preservative to meet the requirements of BS 8417 : 2011 for service in European Hazard Class 4. The infill is specified to provide effective drainage around the crib components.

9.2 This combination, under UK conditions, has been assessed as appropriate for a design service life of 60 years.

Installation

10 General

10.1 The preparation, installation and completion of the Permacrib Retaining Wall System must be in accordance with the Certificate holder's recommendations given in the Permacrib Work Instruction (9.2 PG WI). Excavations must be carried out in accordance with BS 6031 : 2009, with particular attention paid to safety procedures.

10.2 The concrete foundations must be cast with the surface of the concrete left rough to reduce the risk of sliding failure, and the wall erected to give a batter on the wall of one (horizontal) in four (vertical). Construction of the wall must not start until the concrete has reached a minimum strength of $10 \text{ N}\cdot\text{mm}^{-2}$ or twice the stress to which it will be subjected.

10.3 A continuous subsoil drain is, in most cases, provided at the rear of the base slab to carry the water to an outfall.

11 Procedure

11.1 The base line of headers is set out at 750 mm centres and bedded in the green concrete. If necessary, mortar is used to ensure support. A typical layout is shown in Figure 4.

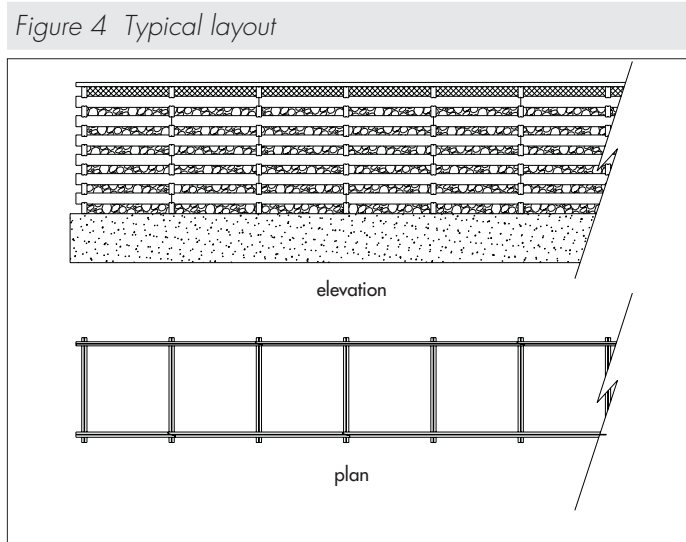

11.2 The first row of stretchers is installed, and, where specified, header support blocks are positioned.

11.3 The next layer of headers is installed on the stretchers directly in line above the base headers. All joints in the stretchers must be tightly butted and with the scarf joints between the stretchers always located at a header position.

11.4 After the construction of a maximum of five courses, but preferably after each course, the units are infilled in layers 200 mm to 300 mm thick. The area behind the wall is progressively backfilled in accordance BS 6031 : 2009.

11.5 Every fifth course the crib frame must be nailed using 75 mm or 100 mm stainless steel nails prior to the granular infill being placed within the wall. When the full height of the wall is reached, a row of stretchers is laid, each on their side, along the top front edge and secured in position with 100 mm long stainless steel nails.

11.6 Infill and backfill must be accordance with section 10.1 of this Certificate.

Technical Investigations

12 Investigations

12.1 The design procedures were examined and compared with established engineering practice.

12.2 Existing information was examined relating to the suitability and retention of preservative.

12.3 A user survey and visits to established sites were conducted to evaluate performance in use.

12.4 Visits were made to sites in progress to assess the practicability of installation.

12.5 The manufacturing process was evaluated, including the methods adopted for quality control, and details were obtained of the quality and composition of the materials used.

Bibliography

BS 6031 : 2009 *Code of practice for earthworks*

BS 8002 : 2015 *Code of practice for earth retaining structures*

BS 8417 : 2011 *Preservation of wood — Code of practice*

BS EN 1997-1 : 2004 *Eurocode 7: Geotechnical design — General rules*

BS EN 1997-2 : 2007 *Geotechnical design — Ground investigation and testing*

Conditions of Certification

13 Conditions

13.1 This Certificate:

- relates only to the product/system that is named and described on the front page
- is issued only to the company, firm, organisation or person named on the front page — no other company, firm, organisation or person may hold or claim that this Certificate has been issued to them
- is valid only within the UK
- has to be read, considered and used as a whole document — it may be misleading and will be incomplete to be selective
- is copyright of the BBA
- is subject to English Law.

13.2 Publications, documents, specifications, legislation, regulations, standards and the like referenced in this Certificate are those that were current and/or deemed relevant by the BBA at the date of issue or reissue of this Certificate.

13.3 This Certificate will remain valid for an unlimited period provided that the product/system and its manufacture and/or fabrication, including all related and relevant parts and processes thereof:

- are maintained at or above the levels which have been assessed and found to be satisfactory by the BBA
- continue to be checked as and when deemed appropriate by the BBA under arrangements that it will determine
- are reviewed by the BBA as and when it considers appropriate.

13.4 The BBA has used due skill, care and diligence in preparing this Certificate, but no warranty is provided.

13.5 In issuing this Certificate, the BBA is not responsible and is excluded from any liability to any company, firm, organisation or person, for any matters arising directly or indirectly from:

- the presence or absence of any patent, intellectual property or similar rights subsisting in the product/system or any other product/system
- the right of the Certificate holder to manufacture, supply, install, maintain or market the product/system
- actual installations of the product/system, including their nature, design, methods, performance, workmanship and maintenance
- any works and constructions in which the product/system is installed, including their nature, design, methods, performance, workmanship and maintenance
- any loss or damage, including personal injury, howsoever caused by the product/system, including its manufacture, supply, installation, use, maintenance and removal
- any claims by the manufacturer relating to CE marking.

13.6 Any information relating to the manufacture, supply, installation, use, maintenance and removal of this product/system which is contained or referred to in this Certificate is the minimum required to be met when the product/system is manufactured, supplied, installed, used, maintained and removed. It does not purport in any way to restate the requirements of the Health and Safety at Work etc. Act 1974, or of any other statutory, common law or other duty which may exist at the date of issue or reissue of this Certificate; nor is conformity with such information to be taken as satisfying the requirements of the 1974 Act or of any statutory, common law or other duty of care.